

# Photodetector and Camera Accessories

Dark Box, Light Sources, Detector Cooling and Sample Control

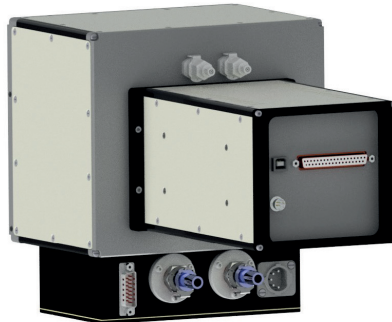
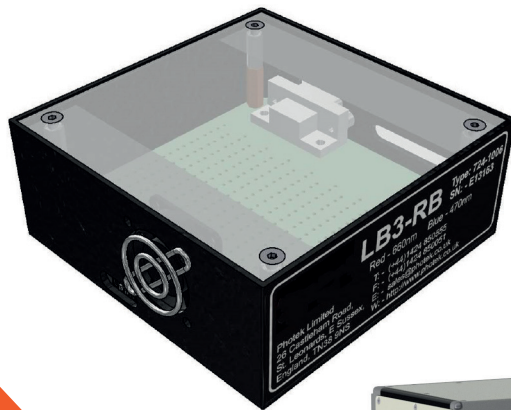

- > DETECT
- > CAPTURE
- > INNOVATE

# Accessories

for Photodetector and Camera systems

Photek Ltd is a leading manufacturer of photon detectors including the industries most extensive line of Image Intensifiers, Imaging Photon Counters and Intensified Cameras.

To help our customers concentrate on obtaining their experimental data, we have developed a line of photodetector peripheral devices including light-tight dark boxes, light sources, detector cooling systems and a temperature controlled sample stage. These devices have been designed to easily integrate with Photek's photodetectors, electronics and Image 32 software.

A complete experimental set-up can be configured and tested as a system prior to shipment, providing confidence that your time will not be wasted trying to get hardware and software to work together. If you require components not shown here, contact Photek's technical experts to discuss your requirements and a customized solution can be proposed. Or, if you are upgrading an existing system, we can help you determine the best detectors and peripheral devices for your application.

**Typical experimental block diagram using accessories, shown in red, found in this brochure.**

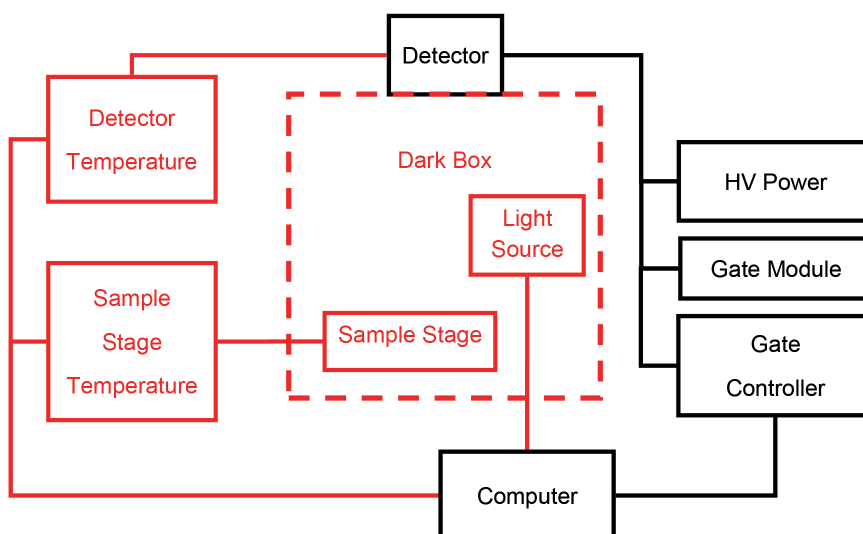

## Features

- > Guaranteed compatibility with all of Photek's photodetectors, intensified cameras and electronic accessories.
- > Control all functions of these devices through the Photek Image32 software, or install Photek provided software drivers for custom integrations.
- > Photek's team of technical experts can help you design the perfect experimental set-up for your application.
- > Extensive experience providing customized solutions based on modifications to the products in this brochure and/or products from long-time industry partners.
- > Industry leading after-sale support to keep your experiments running smoothly.
- > On-site set-up and training available to ensure trouble-free commissioning of catalog or custom systems.

# > DB3 Dark Box

The **DB3 Dark Box** is designed for use with Photek's 25 mm and 40 mm photon counting cameras, but can be adapted to use with any Photek detector. It is fully light tight and suitable for imaging very low light level samples.

The dark box is supplied with a height adjustable stage which allows easy focusing of the sample. One or more LB3 Digital Light Boxes can be fitted into the dark box to provide a multi-wavelength uniform light source for focusing and bright field image acquisition.

The optional TCS2 cooled and heated sample stage provides the ability to control sample temperature between  $-20^{\circ}\text{C}$  and  $+50^{\circ}\text{C}$ .

## Features

- > Fully light tight dark box
- > Easy close door with labyrinth seal
- > Adjustable height sample holder
- > Sample plate lighting (optional)
- > Temperature controlled sample stage (optional)
- > Location templates for MTP and petri-dishes
- > Compatible with all Photek camera systems

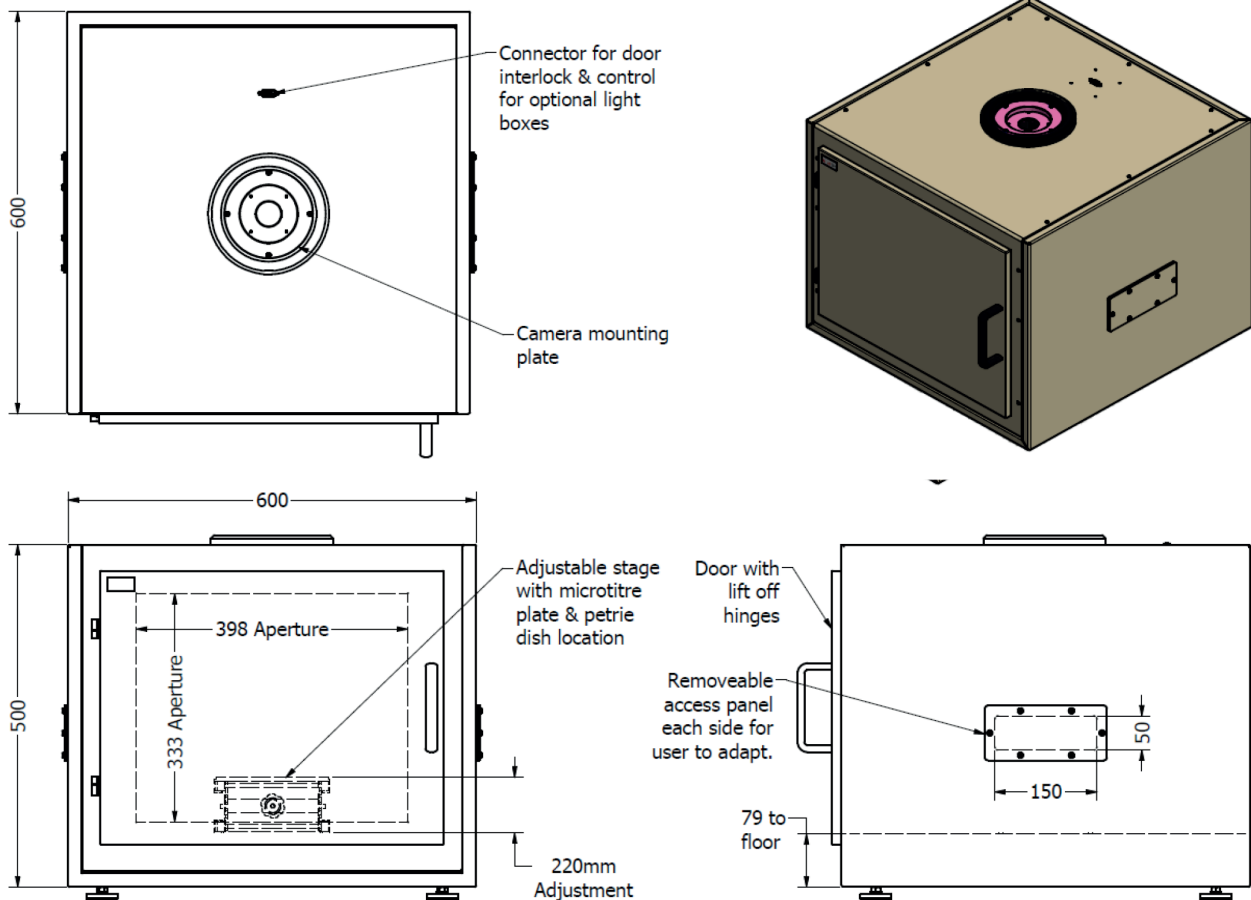

# > Pulsed Laser

The **PLG Pulsed Laser Generator** is designed for time resolved diagnostics of photomultipliers and image intensifiers.

The PLG can test both the time response of high speed photomultipliers and the gating speed of image intensifiers. The PLG features a lens control which allows the beam to be de-focused and spread across the detector area and a variable width control for pulse widths between 40 ps to 800 ps. As standard the PLG is supplied with either a 405 or 650 nm laser, other wavelengths are available on request.

## Applications

- > Time response of high speed photomultipliers
- > Gating measurement of image intensifiers

Specifications	PLG-405	PLG-650
Centre Wavelength	405 nm	650 nm
Line Width	3 nm	3 nm
Pulse Energy	15 - 60 pJ	8 - 100 pJ
Pulse Width	45 - 800 ps	45 - 800 ps
Repetition Rate	Single Shot - 300 kHz	Single Shot - 300 kHz
Trigger-in to Pulse Jitter	3 ps rms	3 ps rms
Sync-out to Pulse Jitter	2 ps rms	2 ps rms
Laser Class	Class 1	Class 1
Power Supply Voltage	+12 V	+12 V
Current (max)	110 mA	125 mA
Height x Width x Length	54 x 61 x 149 mm	54 x 61 x 149 mm
Weight	260 g	260 g

## Features

- > Specifically designed for time-resolved diagnostics of high speed optical detectors
- > Simple to use with only a trigger input and synch output connector
- > A lens control allows the beam to be de-focused and spread across the detector area
- > A variable width control allows pulse widths from 40 ps up to 800 ps

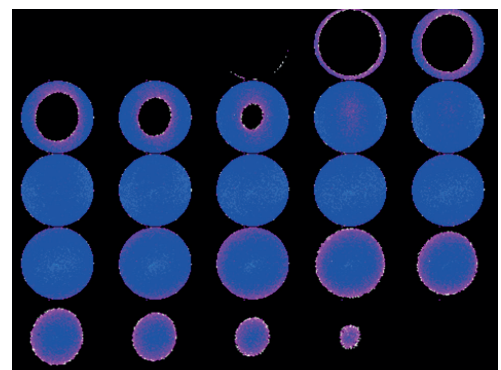

The true optical gating of an image intensifier is observed by synchronising the LPG-405 laser pulse with the gate unit, then adjusting the relative delay and stepping the laser through the gate pulse. This result shows a LPG-405 laser pulse being stepped through a 4 ns gate window generated by a Photek GM200-3N gate unit on a Photek MCP118 image intensifier. Each step represents an extra 200 ps delay on the laser pulse.

# > LB3 Digital Light Box

The **LB3** is a computer controlled, multi-wavelength LED light source perfect for bright field illumination of an experimental sample or as a fixed wavelength light source.

Each LB3 has up to 4 independent channels allowing individual intensity control of up to 4 different wavelengths of LED. The colour/wavelength may be chosen to suit the customers' application, with custom wavelength options available.

The LB3 unit is a lightweight, high intensity light source, designed to be a moveable light source inside an intensified camera system dark box. For units supplied with a Photech camera system control functions are integrated into Photech's Image32 software. Multiple LB3 units may be connected to one USB to RS485 line which allows for independent control of each light box or global control of specific wavelength intensity.

## Features

- > Up to four independently controlled groups of LEDs
- > Wide range of wavelength options
- > Large 50mm x 90mm illumination area
- > Computer control vis easy to use RS485 serial interface, or use Photech's Image32 software with integral LB3 control
- > Multiple LB3 light boxes can be controlled

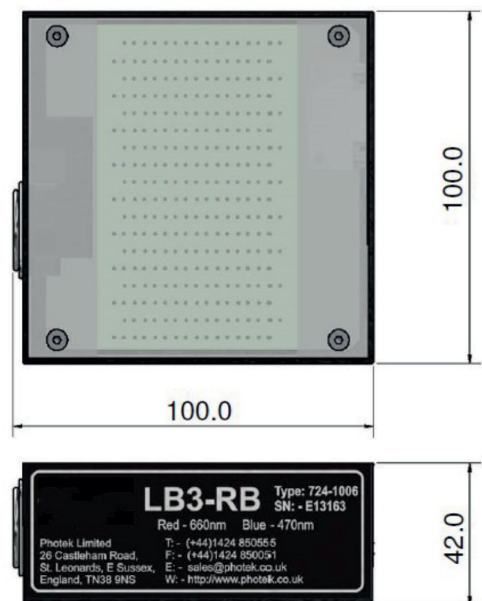
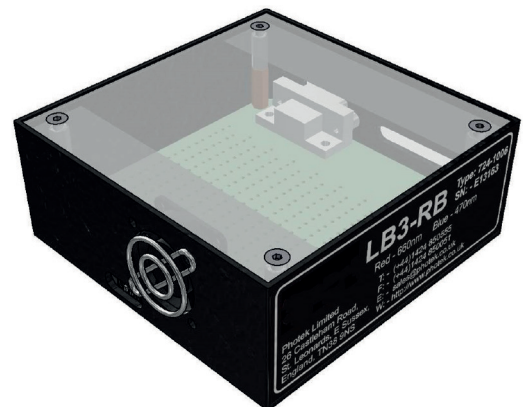

## Specifications

Independent Channels	1 to 4	
Light Area	50 mm x 90 mm	
Wavelengths Available	Blue	470 nm
	Green	568 nm
	Yellow	588 nm
	Red	640 nm
	White	450 - 670 nm
Interface	RS485 (USB connector)	
Number of LB3 per RS485 line	1 to 16	
Power Supply Voltage	+12 V	
Current (max)	1.4 A	
Length x Width x Height	100 x 100 x 42 mm	
Weight	~200 g	
Operating Temperature	0°C to 30°C	

# > Detector Cooling

The Photek **PTC24-2** Temperature Controller is used to control Photek's detector cooling systems, providing operational temperatures of **-25°C or lower**.

This level of cooling can reduce a typical broadband detector's dark noise from around 2000 counts/s to less than 20, with no loss of sensitivity. No other photon detection technology can match this noise performance.

Photek's imaging devices which incorporate cooling are supplied with a Peltier housing around the tube. Set-up is as easy as connecting the cooler housing to either a water supply or re-circulator and the PTC24-2.

The PTC24-2 can be controlled using either a simple to use computer interface or its intuitive front-panel controls. Both the cooling head and heat exchanger temperatures are monitored and provide a safety interlock to prevent damage. Custom configurations are available on request.

Controller	PTC24-2
Cooling Limits	-40°C to +40°C
Typical Cooling Performance	-25°C
Peltier Power Output	24 V @ 2 A
Window Heater Power Output	12 V @ 800 mA
Width x Depth x Height	260 x 280 x 115 mm
Weight	3.1 kg
Supply Voltage	90 V - 260 V 50/60 Hz

Detector Cooler Assembly	
<b>Water Supply</b>	
Maximum Input Pressure	3 x 10 <sup>5</sup> Pa
Minimum Flow Rate	2 L/min
Minimum Head Required	2 m
Water Temperature	~ 15°C
Width x Depth x Height	181 x 155 x 54 mm
Weight	2 kg

## Features

- > Roughly a 100X reduction in dark counts
- > Temperature control and monitoring of the thermal load
- > Safety interlock temperature monitor for the heat exchanger
- > Manual temperature monitoring and control. (Stand-Alone Mode)
- > Computer interface for temperature monitoring and control

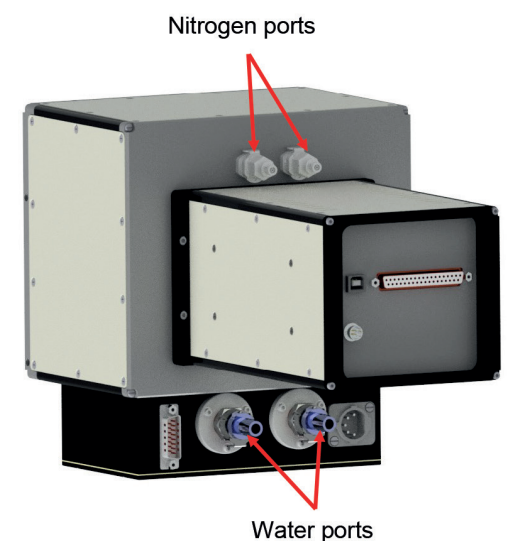
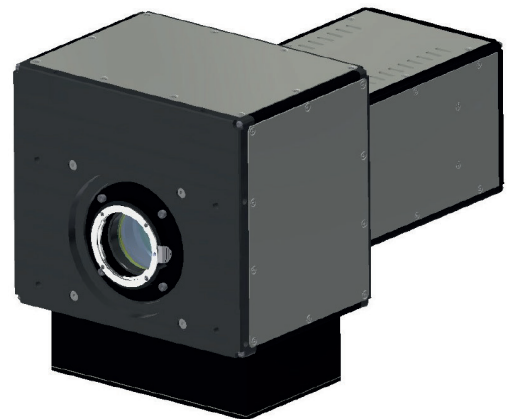

# > Sample Control

The Photek **TCS2 Temperature Controlled Stage** provides a stable thermal environment for a variety of experimental samples. It will typically be used inside the DB2 Dark Box, viewed with one of Photek's intensified cameras or Photodetectors.

The **PTC48-2 Temperature Controller** is specifically designed to control the stage and its sample between -20°C to +50°C. Set-up is as easy as connecting the stage to either a water supply or re-circulator and the PTC48-2 controller. The PTC48-2 can be controlled using either a simple to use computer interface or its intuitive front-panel controls. Both the temperature controlled stage and the heat exchanger temperatures are monitored, providing a safety interlock to prevent damage. Custom configurations are available on request. The cooling system comes with all required cables, water hoses and software drivers to ensure you spend your time on taking data, not hardware set-up.

## Features

- > Temperature control and monitoring of the thermal load
- > Safety interlock temperature monitor for the heat exchanger
- > Manual temperature monitoring and control. (Stand-Alone Mode)
- > Computer interface for temperature monitoring and control
- > Temperature is measured in Degrees Centigrade to 1 Decimal place
- > Capable of heating and cooling samples over a wide range of temperatures

Controller	PTC48-2
Cooling Limits	-20°C to +50°C
Typical Cooling Performance	-10°C
Peltier Power Output	48 V @ 2.5 A
Width x Depth x Height	260 x 280 x 115 mm
Weight	3.1 kg
Supply Voltage	90 V - 260 V 50/60 Hz
Sample Stage	TCS2
Cooled Area	138 mm x 165 mm
<b>Water Supply</b>	
Maximum Input Pressure	3 x 10 <sup>5</sup> Pa
Minimum Flow Rate	2 L/min
Minimum Head Required	2 m
Water Temperature	~ 15°C
Width x Depth x Height	300 x 320 x 45 mm
Weight	5 kg



PTC48-2 Detector Temperature Controller



TCS2 Temperature Controlled Sample Stage

## About Photek

**Photek is a specialist manufacturer of vacuum based tubes and camera systems for photon detection.**

Our product range includes; Camera Systems, Image Intensifiers, Photomultiplier Tubes, Streak Tubes plus a range of associated electronics.

We are experts in large area and ultra-high speed imaging and advanced photon counting camera systems.

Our continuing success is built upon continuous innovation and product development, and by harnessing and applying knowledge to find solutions for all of our customers' applications.

**Photek is accredited to ISO 9001 and ISO 14001.**



## Contact Us

**Our team of specialist engineers and scientists are ready to discuss your application requirements in depth.**

**T:** +44 (0)1424 850 555

**E:** [sales@photek.co.uk](mailto:sales@photek.co.uk)

**Photek Ltd** reserves the right to update and improve this document without prior notice.